

## ***RETURN BIN INDUCTION***



### **CAPABILITIES**

- Multiple item induction
- Repetitive chore eliminated
- RFID check-in
- Labor shift to customer orientation

### **LOCATIONS WITH MODULE**

- Appleton Pub. Lib. - WI
- Cedar Rapids Pub. Lib - IA
- Manitowoc Pub. Lib. - WI
- Pueblo City/Cty Lib. Dist - CO
- Ottawa Pub. Lib. - Ontario, Canada

### **POWER SPECIFICATIONS**

- ½ Hp, 6 gal SilentAir™ compressor used to raise bin floor
- 110VAC, power supplied by system
- Proximity sensors control module movements

### **MODULE DIMENSIONS**

#### SAFETY CAGE

- 48" H x 36" W x 30" D

#### STANDARD RETURN BIN

- 33" H x 29" W x 29" D

#### CUSTOM RETURN BINS

- Book return dimension required for manufacturing
- Photos helpful
- Site-visit suggested

Return Bin Induction offers libraries an economical and unique option to automatically process patron returns from external drop boxes or remote book drops. Specialized bins capable of collecting hundreds of items are emptied onto in-feed conveyors for immediate check-in, separation, singulation and sorting. The optional module dramatically reduces the labor required and time needed to circulate thousands of items per day. Ask staff which they would rather do...

*"Manually induct one item at a time, or hundreds with the push of a button?"*

### **MODULE Includes:**

- Safety cage & docking station
- Push-button control pendant w/ E-stop
- SilentAir™ low pressure air compressor
- Control icon on AMH interface easily adjusts induction rate
- Induction bins sold separately
- Bin sizes are customizable per return location

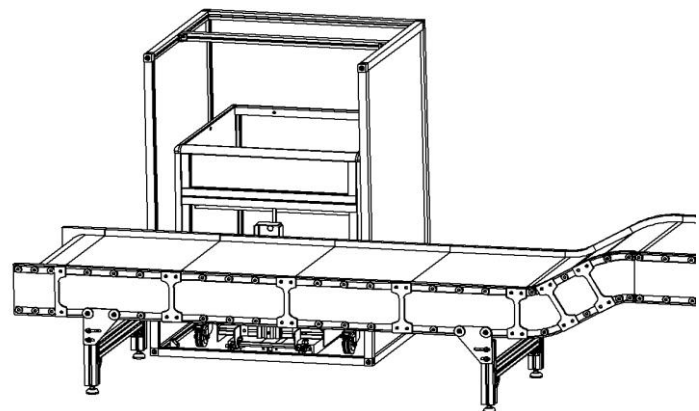

All RFID Library Solution AMH systems are **UL – Certified** and custom designed to meet the unique circulation conditions at each library facility.



**RFID Library Solutions**

11030 89<sup>th</sup> Ave N  
Maple Grove, MN 55369

[www.rfids.com](http://www.rfids.com)

(877) 924-7434